

Hydraulic hand test pump

**Models CPP700-H
and CPP1000-H**

EAC for further approvals
see page 2

Applications

Simple test pressure generation on site,
in the laboratory or in the workshop
For the testing, adjustment and calibration of all
types of pressure measuring instruments
Hydraulic pressure generation up to 700 bar
(10,000 psi) or 1,000 bar (14,500 psi)

Special features

Ergonomic handling
Precise setting through the fine adjustment valve
Compact dimensions
Low weight

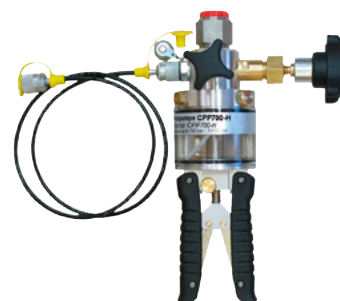

Hand test pump model CPP700-H



Description

Application areas

Test pumps serve as pressure generators for the testing, adjustment and calibration of mechanical and electronic pressure measuring instruments through comparative measurements. These pressure tests can take place in the laboratory or workshop, or on site at the measuring point. The model CPP700-H and CPP1000-H hand test pumps have been specifically developed for test pressure generation on site.

Easy operation

By connecting the test item and a sufficiently accurate reference pressure measuring instrument to the test pump, on actuating the pump, the same pressure will act on both measuring instruments. By comparison of the two measured values at any given pressure value, a check of the accuracy and/or adjustment of the pressure measuring instrument under test can be carried out.

Easy handling

The CPP700-H and CPP1000-H hand test pumps, despite their very compact dimensions, enable simple and accurate pressure generation of up to a max. of 700 bar (10,000 psi) or 1,000 bar (14,500 psi) respectively, with an integrated switching from system pressure to high-pressure generation. For the precise setting for accurate comparative testing, the pump features a fine adjustment valve. As a pressure transmission medium, either hydraulic oil or clean water, free of calcium carbonate, should be used.

The reference instrument is screwed directly to the top of the pump, and the test item is connected using a connecting hose with a G ¼ female thread, included in delivery. The CPP700-H is delivered with a Minimes® 1620 test item hose system as standard.

Hydraulic hand test pump

Models CPP700-H and CPP1000-H

Specifications

Hand test pump		
	Model CPP700-H	Model CPP1000-H
Pressure range	0 ... 700 bar (0 ... 10,000 psi)	0 ... 1,000 bar (0 ... 14,500 psi)
Pressure transmission medium	Hydraulic fluid based on mineral oil or single distilled water ¹⁾ (Water-based hydraulic fluids are not suitable)	
Fluid reservoir	200 cm ³	
Pressure connections		
For reference measuring instrument	G ½ female thread, freely rotating. The connection can be disconnected using an Allen key. Then a G ¾ female thread is available.	
For test item	G ¼ female at test connection hose, length 1 m (3.28 ft), Minimess® 1620 system	G ¼ female, freely rotating at test connection hose, length 1 m (3.28 ft)
Fine adjustment	Fine adjustment valve / volume adjustment	
Material	anodised aluminium, brass, stainless steel, ABS	
Sealings	FKM and NBR (standard)	
Dimensions (L x W x H)	280 x 170 x 120 mm (11.0 x 6.7 x 4.7 in)	
Weight	1,9 kg (4,2 lbs)	

1) Other pressure transmission media on request.

Approvals

Logo	Description	Country
	EAC Pressure equipment directive Machinery directive	Eurasian Economic Community
-	MTSCHS Permission for commissioning	Kazakhstan

Approvals and certificates, see website

Hydraulic hand test pump

**Models CPP700-H
and CPP1000-H**

Front view

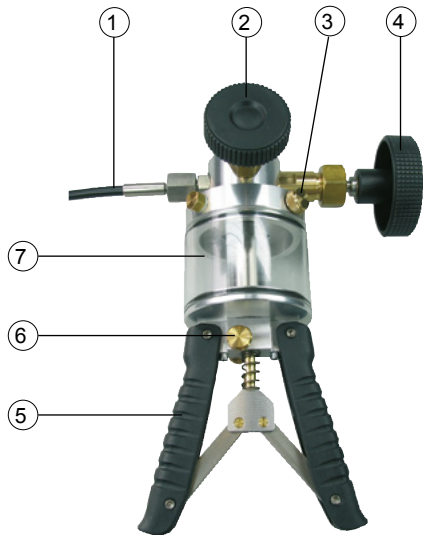

Rear view

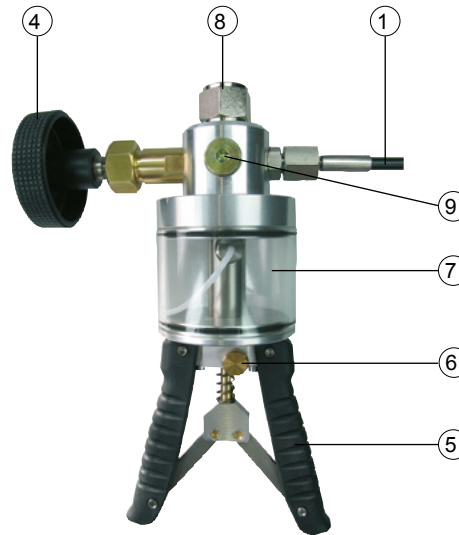

- ① Test item connection hose
CPP700-H: Minimess® system with a G ¼ female pressure gauge connector
CPP1000-H: G ¼ female
- ② Pressure relief valve
- ③ Plug screw for fluid reservoir
- ④ Fine adjustment valve (volume adjustment)

- ⑤ Pump handles
- ⑥ Toggle control, system and high-pressure generation
- ⑦ Fluid reservoir
- ⑧ Connection G ½ female, freely rotating for reference instruments
- ⑨ Blind plug, do not open!

Recommended reference pressure measuring instruments

Precision digital pressure gauge model CPG1500

Measuring ranges up to 1,000 bar (15,000 psi)
Accuracy 0.05 % of span

For further specifications see data sheet CT 10.51



Hand-held pressure indicator model CPH6200

Measuring ranges up to 1,000 bar (14,500 psi)
Accuracy 0.2 % of span

For further specifications see data sheet CT 11.01



Hydraulic hand test pump

**Models CPP700-H
and CPP1000-H**

Hand-held pressure indicator model CPH6300

Measuring ranges up to 1,000 bar (14,500 psi)
Accuracy 0.2 % of span

For further specifications see data sheet CT 12.01



Precision hand-held pressure indicator model CPH6400

Measuring ranges up to 6,000 bar (85,000 psi)
Accuracy up to 0.025 % of span

For further specifications see data sheet CT 14.01



Process Calibrator model CPH6000

Measuring ranges up to 8,000 bar (115,000 psi)
Accuracy up to 0.025 % of span

For further specifications see data sheet CT 15.01



Calibration software

WIKA-CAL calibration software for creating calibration certificates or logger protocols
For specifications see data sheet CT 95.10

Calibration case

Consisting of:
Plastic service case with foam insert
Precision digital pressure gauge model CPG1500
Hydraulic hand test pump model CPP700-H



Hydraulic hand test pump

Models CPP700-H and CPP1000-H

Scope of delivery

CPP700-H

- Hand test pump, model CPP700-H, oil/water
- Minimess® test item hose, length 1 m (3.28 ft)
- Bulkhead connector, G ¼ female
- Operating instructions

CPP1000-H

- Hand test pump, model CPP1000-H, oil/water
- High-pressure test item hose, length 1 m (3.28 ft)
- Connection, G ¼ female
- Operating instructions

Accessories

Adapter set

- Adapter and sealing set, “BSP” for test item hose, G ¼ male to G ¼, G ⅜ and G ½ female
- Adapter and sealing set, “metric” for test item hose, G ¼ male to M 12 x 1.5, M 20 x 1.5 and Minimess®
- Adapter and sealing set, “NPT” for test item hose, G ¼ male to ⅜ NPT, ¼ NPT, ⅜ NPT and ½ NPT female

Case

- Plastic case, incl. foam insert with free spaces for model CPP700-H or CPP1000-H; dimensions (W x H x D): 440 x 370 x 140 mm (17.3 x 14.6 x 5.5 in)

Pressure transmission medium

- Special oil for CPP1000 and CPP1600 test pump series in plastic case, contents 1 litre
- Hydraulic fluid based on VG22 mineral oil in plastic bottle, content 1 litre

Other

- Connection adapter, G ¼ male to G ½ female, material: stainless steel
- Sealing and maintenance set for model CPP700-H or CPP1000-H
- Spare hose for model CPP700-H or CPP1000-H, length 1 m (3.28 ft)

Ordering information

CPP700-H / Package / Adapter set / Case / Special oil / Accessories / Additional ordering information
CPP1000-H / Package / Adapter set / Case / Special oil / Accessories / Additional ordering information