

DTC Initium System

Features

- Support for 8 DTC Series ESP Scanners
- For up to 512 Pressure Channels
- ±0.05% FS Accuracy after Rezero
- 1200 Hz per Channel Throughput Capability in Engineering Units
- Auto-negotiating 10/100 Base-T Ethernet Interface
- Compact Robust Package
- Comprehensive Applications Utility Software
- Field Upgradeable Firmware via Website



DTC Initium System

Applications

Windtunnel Aerodynamic Research



Description

Pressure Systems' DTC Initium provides a powerful yet economical data acquisition system for PSI's DTC series of miniature ESP pressure scanners. This advanced system epitomizes PSI's ambition to eliminate in-situ calibration from electronic pressure scanning technology. The DTC Initium system integrates an advanced analog circuit design with PSI's innovative Digital Temperature Compensation (DTC) technology to maintain optimal accuracy without on-line span calibration. The proprietary technology utilizes a unique sensor mounting technique to enable accurate measurement of bridge resistance for use in real-time correction of thermal errors using personalized compensation algorithms embedded within the scanners. The result is an electronic pressure scanning system that provides state-of-the-art accuracy over the entire scanner operating temperature after only an initial rezero.

The Ethernet-based system directly connects any combination of up to eight 32 or 64 port DTC scanners to facilitate as many as 512 channels of pressure measurements. Multiple systems can be networked for larger channel requirements. The DTC Initium supports software and hardware triggering of data sets, data packet ID stamping for time correlation, and data throughput to the host computer at rates as high as 1200 Hz per channel in engineering units. The system also supports other sophisticated DTC scanner features including programmable deranging capability and internal manifold position sensing. The system operates from a single 18-36 VDC unregulated supply.

Windows® based utility software written in Visual Basic is supplied with the DTC Initium system allowing the user to configure acquisition parameters such as sample rates, averaging, and thermal update rates. It also provides diagnostic tools such as accuracy, channel crosstalk, and leak check routines. The utility software also facilitates firmware upgrades downloaded to the system via Ethernet, which are made available at no charge via PSI's website.

DTC Initium System

Specifications			
Parameter	Parameter	Units	Comments
Pneumatics			
Type of ESPs Supported	ESP-64HD ESP-32HD		DTC Series only
Number of ESPs Supported	1 to 8		any combination of 32 or 64 port scanners
Performance ¹			
Static Accuracy ² @ 100% Range ³	±0.05	%FS	range ≥ 5 psid range ≥ 10 in WC to < 5 psid range < 10 in WC
	±0.10	%FS	
@ 33% Range ⁴	±0.25	%FS	
Total Thermal Error @ 100% Range	±0.10	%FS	range ≥ 5 psid range ≥ 10 in WC to < 5 psid range < 10 in WC
	±0.002	%FS/°C	
@ 33% Range ⁴	±0.004	%FS/°C	
	±0.01	%FS/°C	
	±0.003	%FS/°C	range ≥ 5 psid
A/D Resolution	18	bits	
Measurement Resolution	±0.003	%FS	
Throughput Rate (in Engineering Units)	1200 650 325	Hz/ch Hz/ch Hz/ch	when scanning 16 channels per scanner when scanning 32 channels per scanner when scanning 64 channels per scanner
Communications			
Interface	10/100 Base-T Ethernet		auto-negotiating, half or full duplex
Protocol	TCP and UDP		
Electrical			
Supply Voltage	18-36	VDC	unregulated
Supply Current	1.6 – 0.8	A	typically 1.2A @ 24 VDC with full load
Environmental			
Operating Temperature	0 to 70	°C	
Storage Temperature	-20 to +70	°C	
Relative Humidity	95	%	at 50°C, non-condensing
Physical			
Size	10.00 x 7.00 x 3.50 (254 x 178 x 89)	in (mm)	W x D x H
Weight	3.6 (1.6)	lb (kg)	

- 1) User-selectable system operational parameters such as data averaging and sampling rates enable optimal measurement accuracy to be achieved.
- 2) Static accuracy includes combined errors due to non-linearity, hysteresis, and non-repeatability.
- 3) Achievable static accuracy after rezero. Scanner span calibration recommended at ambient temperature every 6 months to maintain static accuracy specification.
- 4) Accuracy is expressed as a percent of the deranged Full Scale when dual range calibration is specified.

DTC Initium System

DTC Initium Mainframe Architecture

The DTC Initium mainframe features a sophisticated architecture integrating dual embedded microprocessors with innovative scanner addressing logic. This design achieves maximum throughput provided by the electronic pressure scanners. The twin 80 MHz PowerPC microprocessors control segregated tasks within the system. One processor executes engineering unit conversion and handles host communication while the other controls scanner addressing and data sampling. The addressing process routes individual scanner signals through dedicated analog lines to an 18-bit 570 kSPS A/D converter. This configuration avoids all potential restraints in the analog path and assures sampling rates are constrained only by the 50 microseconds settling time required for scanner analog outputs to stabilize within accuracy specifications once a new channel is addressed. Data conversion is executed independent of scanner acquisition, allowing maximum throughput in engineering units to the host computer to be achieved.

Digital Temperature Compensation (DTC)

The DTC option of the ESP pressure scanners incorporates many advanced features to increase the utility of the scanners while providing digital temperature compensation of the silicon sensors. An EEPROM integral to the scanner stores compensation algorithms unique to each sensor. Also stored in the EEPROM is information identifying the pressure range of the scanner, the number of pressure sensors, the model number, the serial number, the date of manufacturer, the date of calibration, and the model and serial number of the calibration unit used to calibrate the scanner. This data is serially transmitted to the DTC System through the ESP address lines. Using proprietary PSI-developed techniques, the pressure sensors are ingeniously mounted to accurately derive bridge resistance as a function of temperature, which is transmitted along with the raw pressure measurements to the DTC System. Utilizing the calibration data within the EEPROM, the DTC System compensates for temperature changes to the sensors in real time reducing thermal error by a factor of 20 over conventional scanners. The ESP scanners also incorporate a hall effect sensor, which is used to indicate the position of the calibration manifold. This position information can be transferred to the system upon command.

DTC Series ESP Pressure Scanners

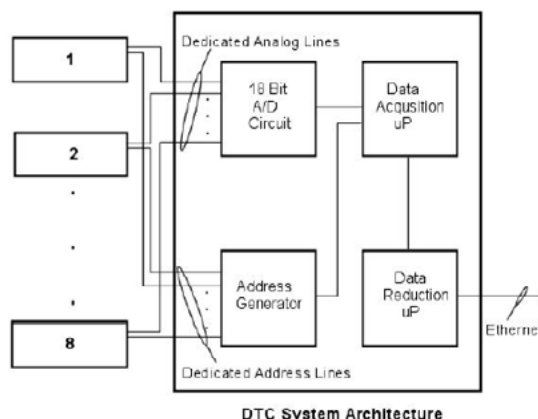

DTC Initium Mainframe Architecture

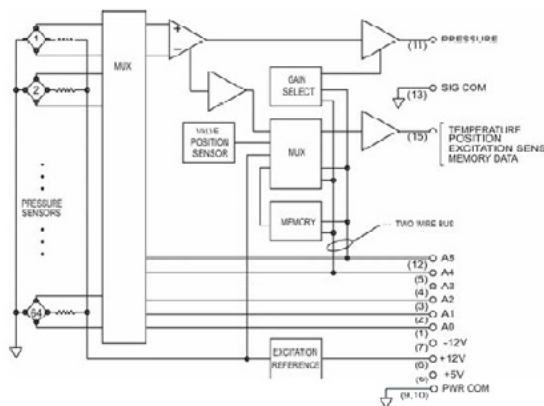

Another advanced feature is the ability to derange the ESP scanner upon command. This alters the gain on the amplifier to derange the scanner by a factor of three, enabling additional windtunnel tests to be conducted without re-instrumenting the model with lower range ESP scanners. To optimize the accuracy of the DTC scanner at the highest gain, the optional dual range calibration is recommended.

DTC Initium System

Software

The DTC Initium Utility Software is a Visual Basic Windows® program that provides the user with general startup operations as well as diagnostic and other utility routines.

General startup routines to run the system and insure proper operation are selected from a menu of available functions on the startup screen. The system can be initialized for custom operation and commanded to run continuous data acquisition for real-time numerical display. Data can also be logged in .csv format for post-run review in Excel or other programs.

Diagnostic routines include operations to confirm system accuracy, assure leak-free operation, and guarantee no channel-to-channel crosstalk. The comprehensive compliment of diagnostic routines are provided to insure system health and enable PSI service engineers to assist customers in keeping systems running properly.

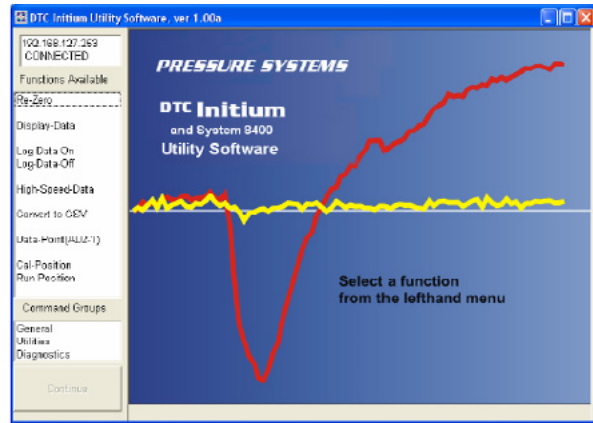

Utility routines include protected scanner EEPROM communication to enable stored data to be evaluated or manipulated as well as system firmware update using downloads offered at no charge from PSI's website.

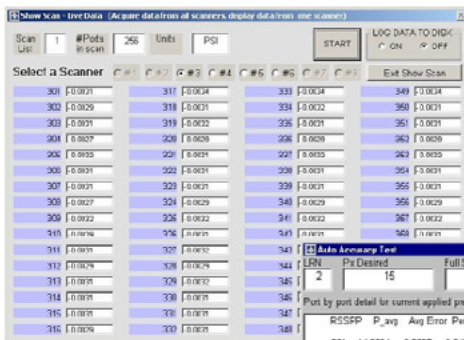

Startup

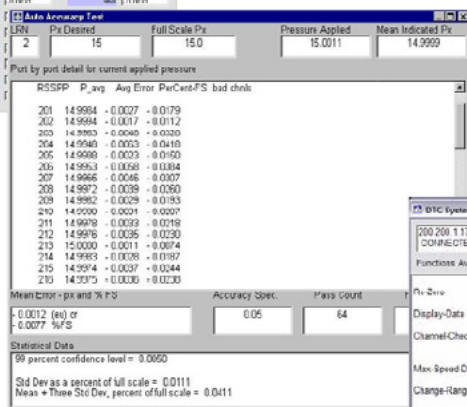

Diagnostics

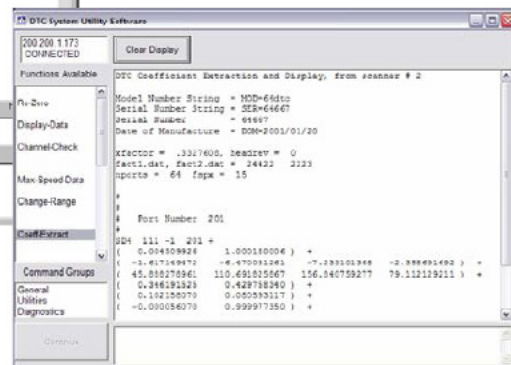

Utilities

DTC Initium System

System Configuration

An example system configuration is illustrated below. Required connections for system operation are simple and few. Power can be user-derived or supplied using PSI's Model 91FC, which provides a convenient interface for power regulation, hardware trigger, and Ethernet communication, all through a 9082 cable to the DTC Initium mainframe. Electrical connection to the DTC Series ESP Pressure Scanners is accomplished using PSCB cables, one for each scanner. An 80-125 psi air source can be supplied to the system to enable the ESP calibration manifolds to be shifted for rezero and/or verification operations under solenoid control within the system.

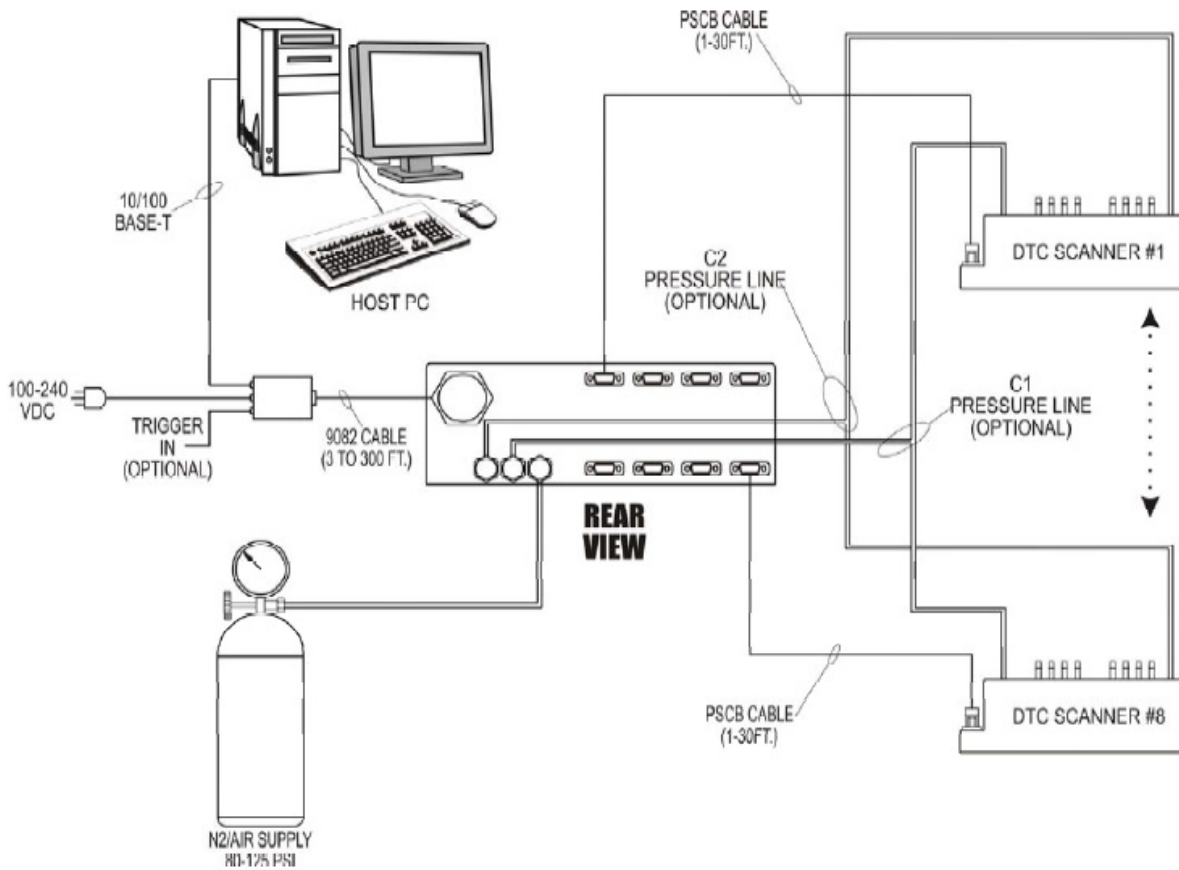



DTC Initium System

Ordering Information

INITIUM-000000000 DTC Initium Mainframe

9IFC-030100000 Host Interface, Universal AC Power

PSCB-AABB00000 Scanner Cable DTC Initium to ESP Pressure Scanner, 30 feet maximum

AA = Length in feet

BB = Material

00, PVC (standard)

01, Teflon

9082-AAAAAAAABB Interface Cable Assembly (5 ft min, 330 ft max)

AAAA(AAAA) = Cable lengths

03000000, 3 feet	00010000, 100 feet	00001200, 210 feet
05000000, 5 feet	00110000, 110 feet	00002200, 220 feet
10000000, 10 feet	00210000, 120 feet	00003200, 230 feet
20000000, 20 feet	00310000, 130 feet	00004200, 240 feet
30000000, 30 feet	00410000, 140 feet	00005200, 250 feet
40000000, 40 feet	00510000, 150 feet	00006200, 260 feet
50000000, 50 feet	00610000, 160 feet	00007200, 270 feet
60000000, 60 feet	00710000, 170 feet	00008200, 280 feet
70000000, 70 feet	00810000, 180 feet	00000003, 300 feet
80000000, 80 feet	00000200, 200 feet	00000033, 330 feet
90000000, 90 feet		

BB = Cable Termination

00	Standard, Circular Twistlock Connections
04	RJ45 and Ring Terminals on Network End of Cable, straight Cat. 5 wiring
05	RJ45 and Ring Terminals on Network End of Cable, cross Cat. 5 wiring

Please refer to ESP-HD Datasheet for part numbering information.